

RCS

**Model TZ43
ZWave Thermostat**



**INSTALLATION
AND
OPERATION MANUAL**

DCN: 141-01652-03

9/22/08

***** IMPORTANT NOTICE *****

DO NOT USE THIS PRODUCT FOR BUILDING FREEZE PROTECTION! YOU ARE ADVISED TO
INSTALL A MECHANICAL FREEZE PROTECTION DEVICE ON YOUR SYSTEM FOR THIS PURPOSE.

Model: TZ43
ZWave Thermostat

This manual applies to the following product revisions or later revisions up to the next manual revision release:

Product	Part No:	Firmware
ZWave Thermostat	001-01652-01	

Document Revision History

Revision	Date	Changes
01	7/30/08	Original release
02	8/22/08	Updated Zwave Install description
03	9/22/08	Updated Zwave command class information

Product Specifications

Product Model: TZ43
Product: Thermostat for Heating and Cooling HVAC System control.
ZWave RF communications enabled

Thermostat

Size: 5.7" wide x 4.0" height x 1.2" depth
Display: Graphical LCD, 2.75" x 1.5", 64x128 pixel
Backlight: Yes, Blue/white, Controllable, on, off, timeout
Contrast: adjustable on screen
Buttons: 6
LEDs: 4 (3 green, 1 red)
Temp sensors: 2 remote
Power: 24VAC from HVAC System

HVAC System Type Compatible: Standard (gas/electric) or Heat Pump
Multistage System Compatible:
Standard HVAC Systems: 2 stage heating, 2 stage cooling
Heat Pump Systems: 3 stage heating (2 compressor, 1 aux), 2 stage cooling
Heat Pump change over valve: Selectable change over with cool or with heat

Outside temp sensor: 2 wire, 10K NTC thermistor type
Communications: ZWave RF

Table of Contents

Overview	4
Z-wave® Programming and Operation	5
Operation	6
Thermostat Control Screen	7
Temperature Display	7
Setpoint Display	7
Clock Display	7
Outside Temperature Display (optional)	7
Thermostat Control Screen Buttons	8
LED Displays	10
Main Menu	11
Schedules Screen	12
User Settings Screen	15
Thermostat Info Screen	21
Main Menu > Installer Settings (Hidden Screen)	22
Installer Settings Summary	25
HVAC System Connection	27
HVAC System Compatibility	27
Remote Communications	27
Outside Temperature Operation	27
HVAC System Operation and Setup	28
Standard HVAC System Types	28
Heat Pump HVAC System Types	28
Remote Temperature Sensors	30
Power	31
Standard Gas/Electric HVAC System Wiring	32
Heat Pump HVAC System Wiring	33
HVAC SYSTEM QUICK TEST	34
ZWave Command Class Information	36
TZ43 Variable Table	36

TZ43 Thermostat

The TZ43 thermostat provides for typical thermostat control of a central heating and cooling HVAC system plus has the added feature of ZWave communications for remote control.

The thermostat has a large, backlit graphical display, control buttons, status LEDs and a temperature sensor. The thermostat can display multiple screens for different functions of the thermostat. In the default thermostat control screen, shown below, it displays the current temperature, setpoint, system mode, manual fan mode, time, outside temperature and other information.

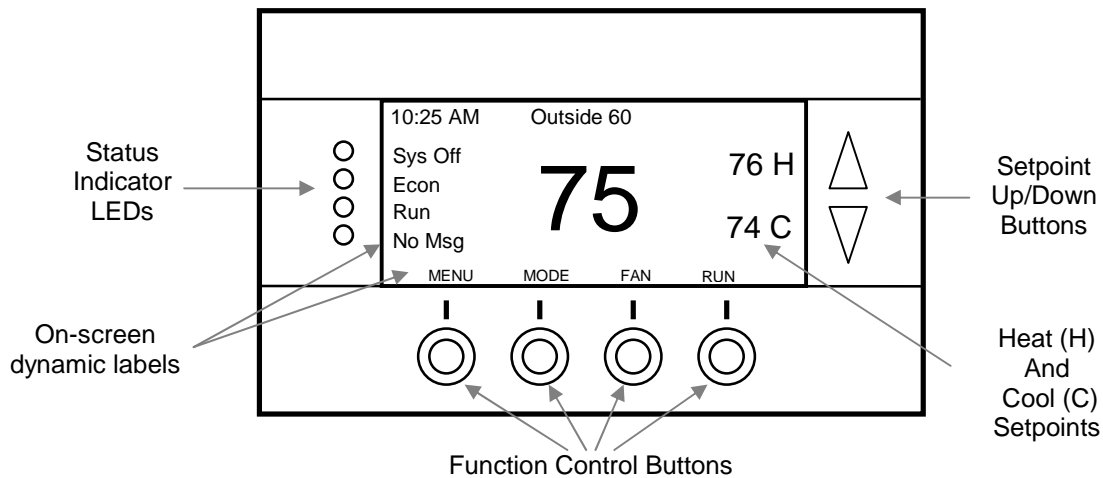

Display operation

Thermostat control screen

Normally the thermostat displays the thermostat control screen as shown above. Using the "Menu" button, you can access other screens and functions of the thermostat.

Minimized Display Mode

Optionally, you can set the thermostat to show only the temperature in a "minimized" display mode. This mode can be set on or off in the thermostat "Users Settings" screen.

Other screens

Other standard screens are selected by the Menu button and include: Schedules, User Settings, and Thermostat Info. Other screens, such as the SmartVent ventilation control screen, may be present and selectable from the menu button depending on options included or selected in the installation setup process.

Backlight

The thermostat has a backlit display for low light and night visibility. It can be set to remain on constantly, or to turn off after a 20-45 second delay. These are selectable in the User Settings menu.

Z-wave® Programming and Operation

Z-Wave controllers from various manufacturers may support the Z-Wave Thermostat General V2 Device class used by the RCS TZ43 Thermostat. The following procedure will allow the thermostat to be added to a Z-Wave network.

General Programming Procedure (for controllers supporting the thermostat device class):

1. Set your primary controller to Include mode, to add the thermostat as a node on your network (see your controller's user manual for detailed instructions).
2. Navigate to the Z-Wave Install Button screen. This screen is located in the Installer Screen. **To enter this screen, go to the main menu screen and press and hold the two inner buttons for 3 seconds until the Installer Settings screen appears.** Scroll down until the Z-Wave Install Btn menu item is selected, press the Select button.
3. Press the YES button.

Your controller will indicate the thermostat was successfully added to its network (see your controller's user manual for details). Also you can check if the thermostat was successfully added to the network by checking the ZHID (Home ID) and ZNID (Node ID) located in the Thermostat Info screen.

For other specific tasks such as adding the thermostat to Scenes or Groups, or deleting the thermostat from an existing network, use the Z-Wave Install Button procedure.

Note: Before adding the thermostat to a Z-Wave Network, check that it does not already belong to one by viewing the Home and Zone ID's located in the Thermostat Info screen. An unconfigured thermostat should show zeros for both the Home and Zone IDs. Consult your controller's user manual for details on removing a device from a Z-Wave network.

Thermostat Control Buttons

The Thermostat buttons are “Soft Keys” meaning that they change functions when you change screens. The function of the button is defined by “on-screen labels” that are dynamic and change when you change screens.

LEDs

The Thermostat has four LED's that displays status information. The LEDs have dynamic “on-screen” labels that can change with the screen being displayed.

“Screens”

A unique feature of the Thermostat graphical display is the ability to have multiple display screens. In addition to a main thermostat control screen, menus and other control screens for special functions are provided. This makes an intuitive and easy to use “user interface”. It allows the many functions of the Thermostat to be easily navigated.

The main screen is the Thermostat Control Screen. From this screen you can access a menu screen that will list other control screens or setup screens.

Thermostat Control Screen

This is the default main screen and the only screen needed for basic thermostat operation (temperature setting and heat/cool mode selection). All other screens will automatically timeout and return this screen after 120 seconds of no activity.

Minimized Thermostat Screen

The main thermostat screen will go to a “minimized” screen after a 30 second timeout period. This presents a simple uncluttered display of the current room temperature and outside temperature (if an OT sensor is attached). This minimized screen can be disabled if desired.

Pressing any button when the minimized screen is displayed will causes the Thermostat Control screen to be restored and displayed.

Menu Selection Screen

Pressing the Menu button on the Thermostat Control Screen will go to the Menu Selection screen. This screen presents a list of the other functions or setup screens that can be selected.

Schedules Screen

This screen is used to view and edit the time based setback schedules for the thermostat.

User Settings Screen

This screen is a submenu of user settings for the initial setup of the thermostat. You can set the clock, minimized screen timeout, Fahrenheit or Centigrade selection, sensor calibration and display settings.

Thermostat Info Screen

This is a quick reference list of the thermostat firmware versions and setup.

Each Thermostat screen is described in more detail in the following sections.

Thermostat Control Screen

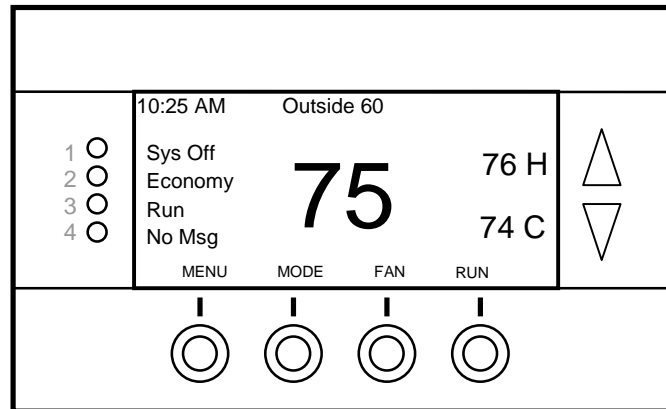

The thermostat control screen is the default display screen and is the screen that is normally displayed on the Thermostat. It can be set to switch to a minimized screen of only room temperature after a few seconds of display. The User Settings menu allows selecting the screen timeout for a minimized screen.

From the “minimized screen” display, **pressing ANY button** will bring the main thermostat screen back.

Temperature Display

The Thermostat will normally display the current temperature from the internal temperature sensor or a remote sensor. The sensors have an accuracy of +/- 1°F (+/- .5°C). The Thermostat temperature range is -63°F to 191°F.

NOTE: If averaging remote sensors are attached, the display will show the average temperature of all attached averaging sensors.

Setpoint Display

The heating and cooling setpoints are displayed next to the Setpoint Up/Down buttons. In the HEAT mode, the Up/Down buttons change the heat setpoint. In the COOL mode, they change the cooling setpoint. When in AUTO mode, the buttons change the last call's heating or cooling setpoint. Note that the setpoints will “push” each other if they are adjusted to get within the minimum Heat/Cool separation setting. This is normally 4 degrees.

Clock Display

The current time is displayed in the upper left corner of the main screen. Set the clock from the User Settings Menu.

The time will blink when the clock has not been set.

Outside Temperature Display (optional)

The outside temperature is displayed in the top center of the main screen, if an outside temperature sensor is attached to the Thermostat Remote Sensor RS2. Requires outside sensor, Model OS5, be installed and RS2 to be configured as OUT in the Installer Settings.

Thermostat Control Screen

Thermostat Control Screen Buttons

UP and DOWN Buttons

The **UP** and **DOWN** buttons adjust the setpoint temperature. Pressing the UP button will increment the setpoint value by one degree and conversely, pressing the Down button will decrement the setpoint one degree. Pressing and holding a button down will cause the setpoint to continuously change until the button is released.

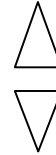

Setpoint Range: The setpoints can be set from 40°F to 106°F (5°C to 37°C), *unless limited in the Installer Settings.*

Setpoint Push: Note that you cannot lower the cooling setpoint below the heating setpoint. The thermostat will “push” the heating setpoint lower if you try to lower the cooling below the heating setpoint. It maintains a 3 degree separation between the heating and cooling setpoint. The same is true for raising the heating setpoint above the cooling setpoint. Again the thermostat will “push” the cooling setpoint up to maintain the 3 degree separation.

NOTE: *If the system mode is OFF, the setpoint buttons will not change the setpoints. To change the Heat Setpoint you must be in Heat mode, to change the Cool Setpoint you must be in the Cool mode.*

MENU Button

The Menu button changes the screen display to the MAIN MENU screen which show what other functions are available on the Thermostat. These are dynamic and can change with the version of the thermostat you have, but the standard ones include:

Main Thermostat Screen

→ Menu Button

- Main Menu Screen
 - Messages
 - Schedules
 - User Settings
 - Thermostat Info

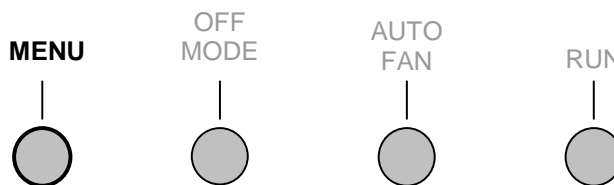

MODE Button

The **MODE** button controls the HVAC system mode. The current mode selected is displayed above the button. Pressing the **MODE** button will cause the mode and display to change to the next mode. The system mode cycles from **Off** to **Heat** to **Cool** to **Auto** and back to **Off** again with each press of the **MODE** button. When the HVAC system type is set to Heat Pump, the mode selection will include **EHEAT** for Emergency Heat mode.

→ Mode Button

- Off
- Heat
- Cool
- Auto
- EHEAT (HP system only)

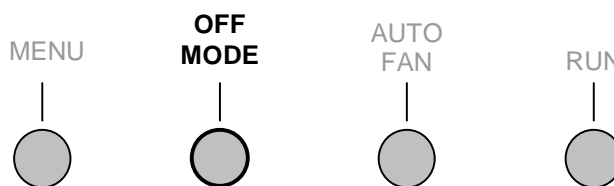

Thermostat Control Screen

Mode Button Operation

Off Mode: System is off. No heating or cooling will come on. If system was on, it will turn off.

Heat Mode: Only heating will occur.

Cool Mode: Only cooling will occur.

Auto Mode: Heating or cooling will come on according to the heating and cooling setpoints. The system will automatically switch between heating and cooling when the temperature exceeds the appropriate setpoints.

EHEAT Mode: Emergency Heat mode is only displayed when **Heat Pump** HVAC System type is selected. When there is a compressor failure with the heat pump system, setting the mode to EHEAT will allow the supplemental heat to come on whenever there is a heat call to provide heating. It also disables the compressor outputs to prevent further damage to the system.

FAN Button

The **FAN** button controls the HVAC system's **MANUAL** fan. The current manual fan mode is displayed above the button. Normally this button is in the Auto mode (the system fan is automatically controlled by HVAC system). Pressing the **FAN** button once will turn the manual fan operation ON. Pressing it again will turn the manual fan OFF and return to the AUTO mode (under control of the HVAC system).

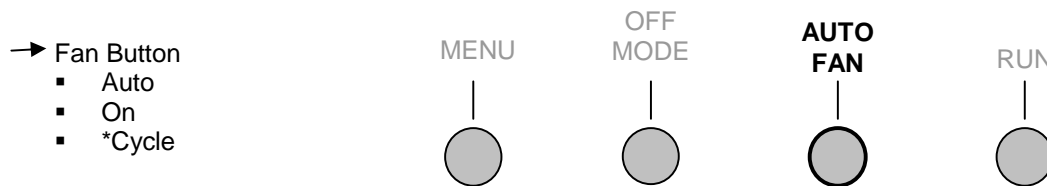

*If the Fan Cyclers feature is enabled the additional fan mode "Cycle" will be available

RUN/HOLD Button

The **RUN/HOLD** button controls the automatic **SCHEDULE** operation. In the HOLD mode, the current temperature is maintained until changed by manual or remote network command. In the Run mode, the schedule loaded into the thermostat is activated and setpoints will change according to the schedule and the time and day of week.

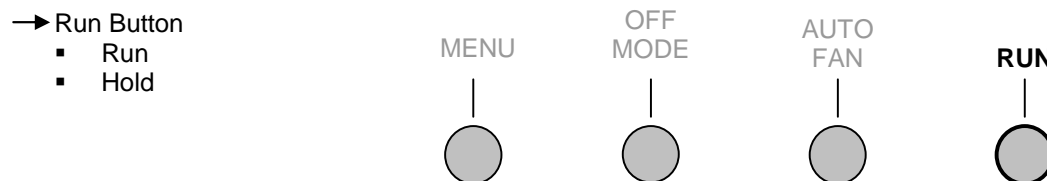

LED Displays

The Thermostat Control Screen has the following LED labels and descriptions, numbered from top to bottom, 1-4.

- **LED 1 Green: System Operation display.**
 - LED Off, "SYS OFF" displayed > HVAC system is OFF
 - LED Off, "SYS MOT" displayed > Minimum Off Time (MOT) delay on is active
 - LED On, "SYS ON" displayed > HVAC System is running
 - LED On, "SYS MRT" displayed > Minimum Run Time (MRT) delay off is active
- **LED 2 Green: System Economy Mode display**
 - LED OFF, "Econ" displayed > Economy or 1st stage heating or cooling only
 - LED On, "2nd Stg" displayed > Stage 2 heating or cooling is active
 - LED On, "Aux Heat" displayed > Stage 3 heating is active
- **LED 3 Green: Run/Hold display.** Shows state of Schedule Run/Hold Mode.
 - LED Off, "Run" displayed > Setback schedule is running
 - LED On, "Hold" displayed > Schedule is off, temperature setpoint hold in effect.
- **LED 4 RED: Alert LED.** Used for other system alerts
 - LED Off, No Alerts present
 - LED On, Alert Text displayed > Specific alert text

Main Menu

The Thermostat has a menu tree that can be accessed by pressing the “Menu” button on the Main Thermostat screen. Various configurations of the Thermostat can have different screen contents. The first screen that will come up is the Main Menu screen. This is a list of the other menus or functions that can be accessed. Standard screens are listed below. Yours may vary with different configuration or revisions. Optional screens are selected in the Installer Settings screen during the system setup.

Schedules Screen: This screen is used to view and set the programmable setback schedules of the thermostat.

User Settings Screen: This screen is used to set the Clock, Filter Service, Maintenance Service, Screen Timeout, F/C mode, Sensor Calibration and Backlite/Display settings.

Thermostat Info Screen: This screen shows the firmware versions of the Thermostat and Zwave interface, HVAC system type and equipment options.

Main Menu

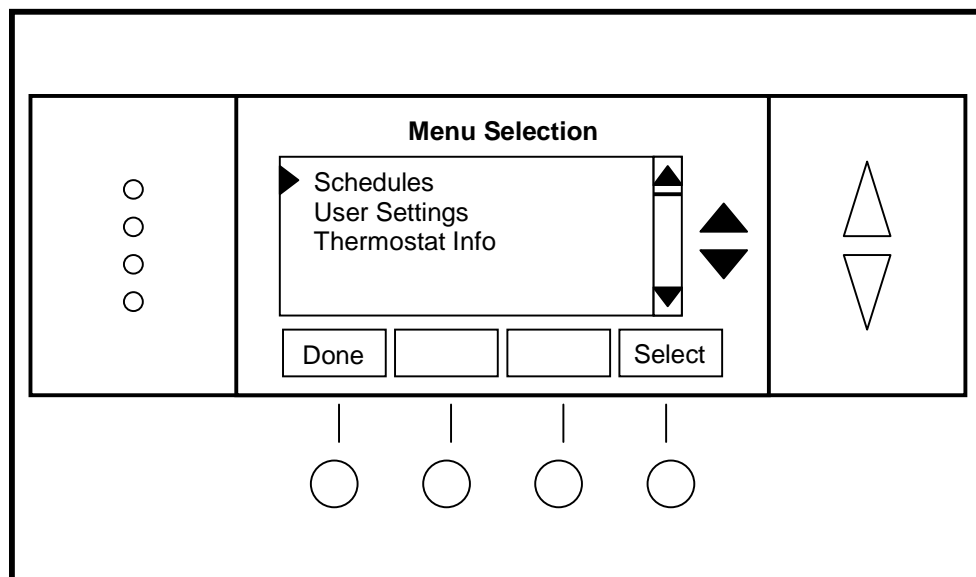

Screen navigation buttons:

Done	Return to Thermostat Screen
	Not used
	Not used
Select	Select menu item at pointer

	Move menu selection pointer up
	Move menu selection pointer down

Main menu - Schedules

The Schedules Screen allows you to review and set the setback schedule for the thermostat. The thermostat has a 4 x 7 schedule. Four times a day can be selected for changes to the heating and cooling setpoints. Each day of the week can have a different schedule. Groups of days can be copied with the same schedule. When the thermostat is set to "Run" mode, the schedule will be executed daily, with the setpoints being changed as per that days schedule stored in the thermostat. "Hold" mode stops schedule operation and holds the current setpoints until changed manually or by network commands.

The Schedules Screen gives you the option of setting a custom setback schedule or to load one of two preset schedules.

Menu Options

- **Heat and Cool:** You can change the individual day/hour and setpoints for the Heating and Cooling schedule by selecting this menu item.
- **Preset: Comfort:** This is a preset schedule with mild setbacks. Select this menu item to load the Comfort schedule into the thermostat.
- **Preset: EnergyMiser:** This is a preset schedule with deeper setbacks. Select this menu item to load the EnergyMiser schedule into the thermostat.

Schedules Screen

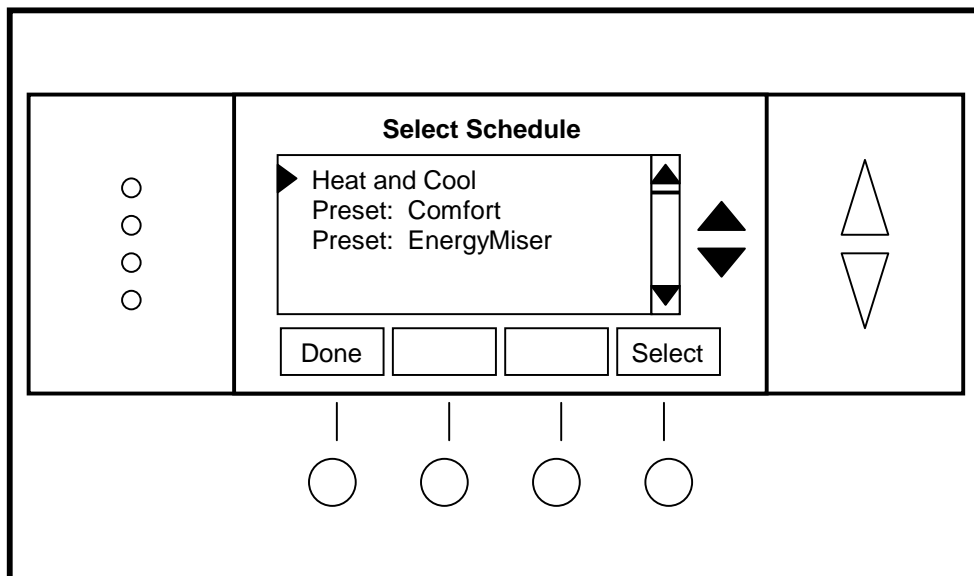

Screen navigation buttons:

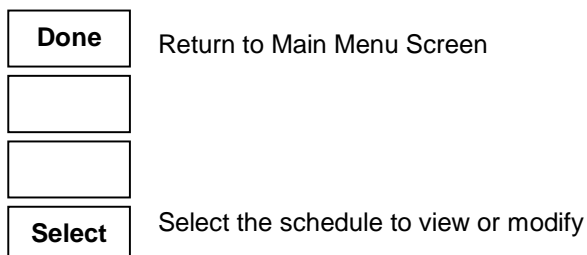

Main Menu - Schedules - Heat and Cool Schedule Screen

When you select the Heat and Cool Schedule menu item, the “day” Schedule programming screen opens and the schedule for current day will be displayed. Use the scroll buttons to highlight the data to be modified. Once the data has been highlighted, use the +/- buttons to change the value of the data.

To copy a days schedule to another day or group of days, move the cursor to “c” on the bottom right of the schedule screen. When you highlight the “c”, the button below will become “Copy”. Press this button to change to the Copy Schedule Screen.

Schedule Screen

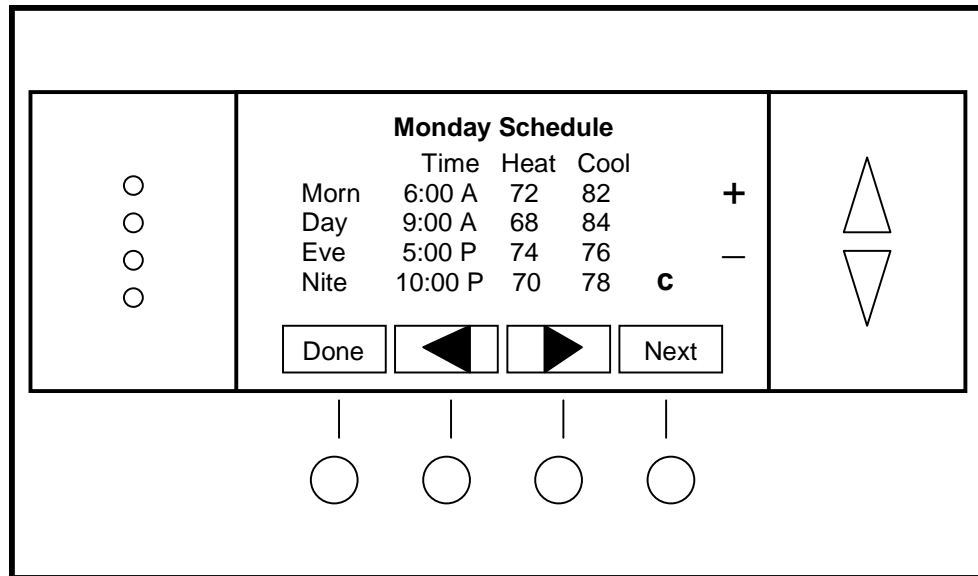

Screen navigation buttons:

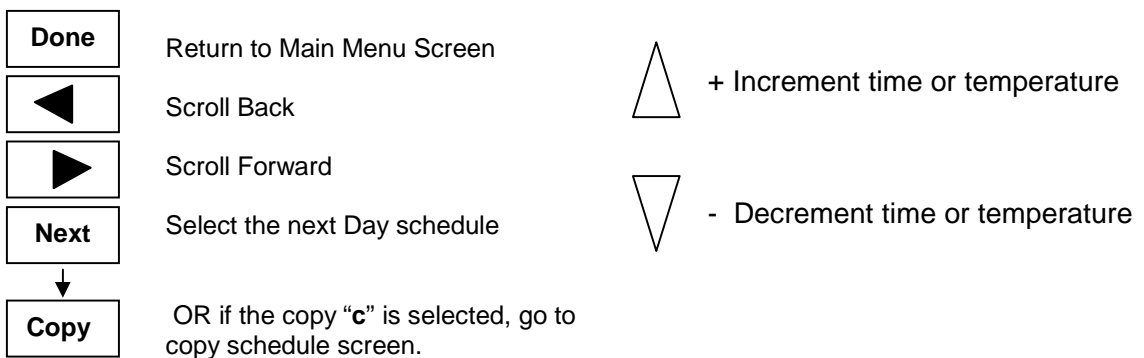

Main Menu - Schedules - Heat and Cool - Copy Schedule

The Copy Schedule screen is a sub screen of the Schedule screen. The Copy Schedule screen allows you to copy a day's schedule to another day or group of days.

First select the day to be copied in the Schedule screen. Scroll to the "c" at the bottom of the Schedule screen to highlight it. The "Next" button will change to the "Copy" button. Press the "Copy" button to open the Copy Schedule screen.

Scroll through the days and select the days you want to copy the schedule to by setting the "N" under each day to "Y" by using the Yes/No buttons.

After selecting all the days desired, press the "Copy" button.

Exit the Copy Schedule screen with the "Back" button.

Copy Schedule Screen

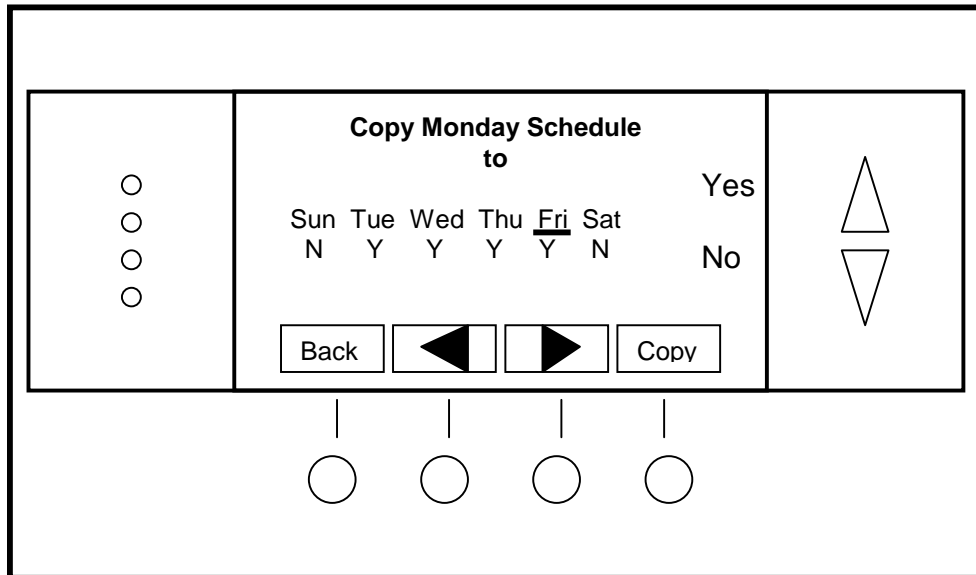

Screen navigation buttons:



Back

Return to Schedule Screen



Move back with selection bar



Move forward with selection bar



Copy

Copy the schedule to the selected days



Yes - Copy schedule to this day



No - Do not copy to this day

Main Menu - User Settings

The User Settings screen allows you to set or change various user options of the thermostat such as the Clock, Minimized Screen timeout, Fahrenheit/Celsius mode, Sensor Calibrations, and Display settings.

Menu options:

- **Set Clock:** Select this menu item to go to the Clock setting screen.
- **Filter Service:** Sets/resets the filter timer/alert.
- **Maint Service:** Sets/resets the maintenance timer/alert.
- **Screen Timeout:** Select the Screen Timeout time in seconds. Options are 0 or 15 to 127 (default set to 0 seconds). This is the time before any screen reverts to the **Minimized Screen** (temperature display only), after you stop pushing buttons. Minimized Screen feature is disabled by setting this time to "0".
- **F/C Mode:** Select which temperature display mode you desire, Fahrenheit (F) or Celsius (C).
- **Sensor Calibration:** Select this menu item to go to the Sensor Calibration screen.
- **Backlite/Display:** Select this menu item to go the Backlite/Display settings screen. This menu allows you to set the backlight timeout period and adjust the display contrast.
- **Usage Graph:** Select this menu item to display a Usage Graph that will show the runtime accumulation of Heating and Cooling cycles.

User Settings Screen

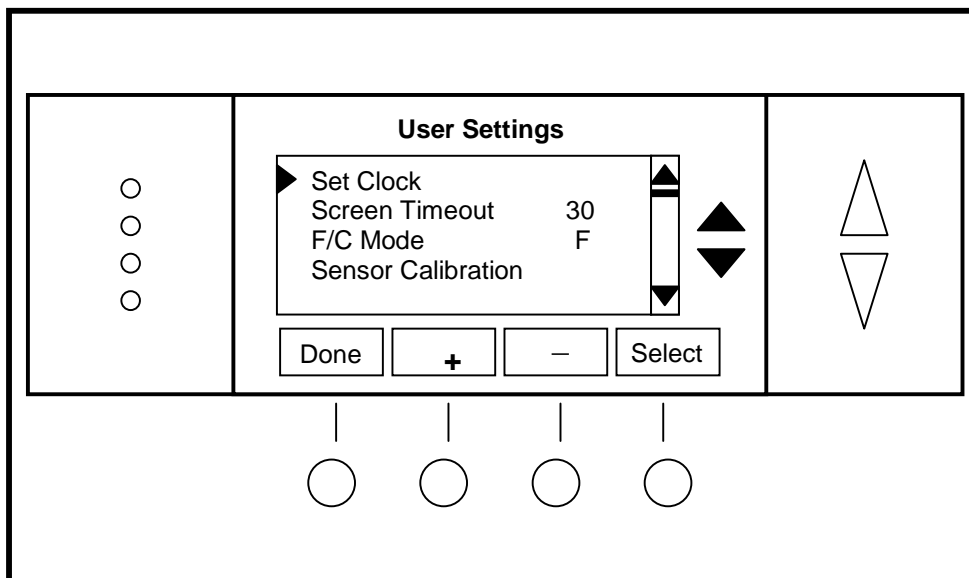

Return to Main Menu

Increment value

Decrement value

Select the function to be set



Move menu selection pointer up



Move menu selection pointer down

Main Menu - User Settings - Set Clock

The Set Clock screen allows you to set the Thermostat's internal clock.

To set the Time and Date, move the cursor with the navigation arrows until the data you want to change is highlighted.

Using the + and – buttons to increment or decrement the data to the desired setting.





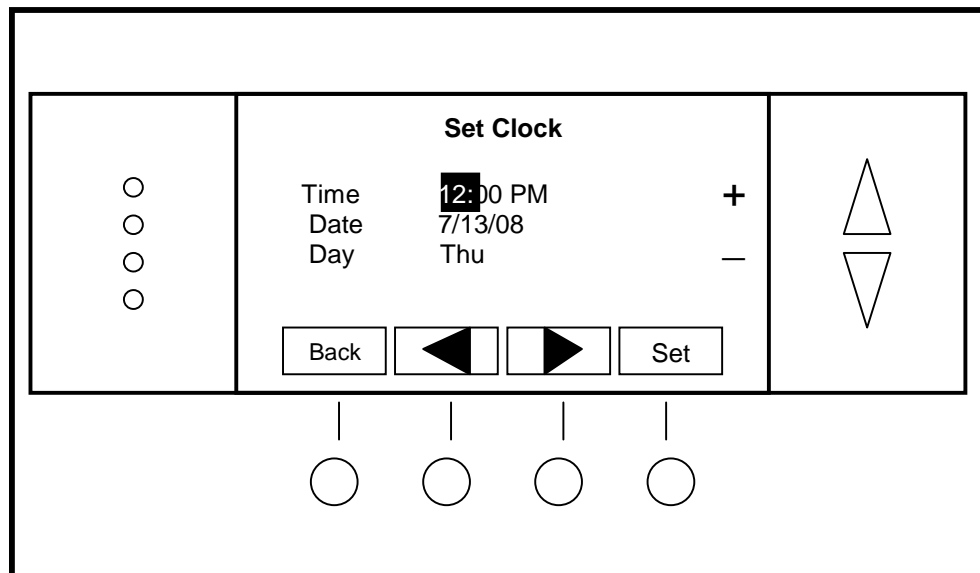

When finished, press the **SET** button to return to the Main Menu screen or wait for screen to timeout.

NOTE: If the clock has been reset by an extended power outage, the Clock display on the thermostat screen will be blinking. Pressing the MENU button will take you directly to this screen to set the clock.

Set Clock Screen



Screen navigation buttons:

	Cancel and return to User Settings Menu		+ Increment selected item
	Move back with selection box navigation arrow		
	Move forward with selection box navigation arrow		- Decrement selected item
	Set the time and return to User Settings Menu		

Main Menu - User Settings - Filter Service

The Filter Service screen will show the accumulated Filter Runtime hours as well as the Service Interval that will be used to trigger a Filter Message. Any type of HVAC operation that causes the HVAC system fan to run will cause the Filter Runtime value to increase.

When the Runtime hours equals the Service Interval hours, the Red LED will flash along with a "Filter" message to remind you to replace the filter. Pressing the Menu button will take you to the Filter Service screen. Once the filter has been replaced, press the Reset button to reset the Filter Runtime value to zero.

The Service Interval period can be changed using the +/- buttons.

Filter Service Screen

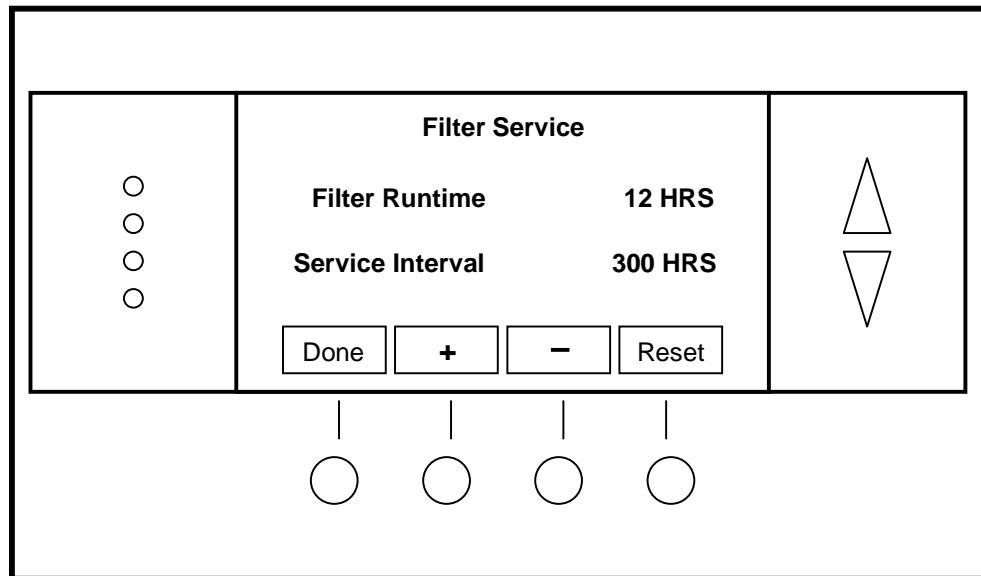

Screen navigation buttons:

Done	Return to Main Menu Screen
+	Increase the Service Interval by 1 hour
-	Decrease the Service Interval by 1 hour
Reset	Reset the Filter Runtime Timer

Main Menu - User Settings - Maint Service

The Maintenance Service screen will show the accumulated Heat and Cool Runtime hours as well as the Service Interval that will be used to trigger a Maintenance Message. Any HEAT or COOL type of HVAC operation will cause the respective Runtime values to increase.

When the combined HEAT and COOL Runtime hours equals the Service Interval hours, the Red LED will flash along with a "Maint" message to remind you your HVAC system may require periodic maintenance. Pressing the Menu button will take you to the Filter Service screen. The Reset button can be pressed and the HEAT and COOL Runtime values will be reset to zero.

The Service Interval period can be changed using the +/- buttons.

Maintenance Service Screen

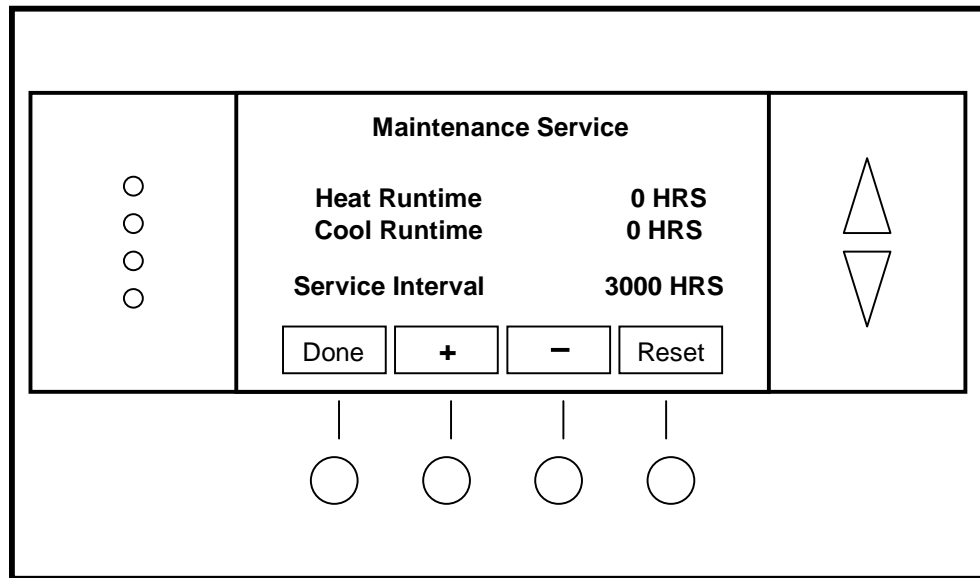

Screen navigation buttons:

Done	Return to Main Menu Screen
+	Increase the Service Interval by 1 hour
-	Decrease the Service Interval by 1 hour
Reset	Reset the Heat+Cool Runtime Timers

Main Menu - User Settings - Sensor Calibration

The Sensor Calibration screen allows you to change the temperature calibration for the internal and any external remote temperature sensors attached to the Thermostat. You can change the temperature calibration by +/- 7 degrees.

When the Sensor Calibration screen is selected it will show the internal and all **detected** remote sensors. Each sensor found will show the current temperature (The (75) in the example screen below) and the current number of degrees of offset being applied (1 deg in the example). "n/a" means that the remote sensor is not attached. If the sensor's actual temp is (74) with 0 degrees of offset and you want it to be 75, then press "+" to add 1 deg and it will show (75).

To change the temperature calibration, use the scroll buttons to select the internal or a remote sensor. Once selected, use the + and - buttons to change the temperature calibration to the desired setting.

The value shown in the (xx) is the calibrated or offset temperature that you want the sensor to show.

You can refresh the info on this screen by pressing the right hand (blank) button.

When you close this screen, it may take a few seconds for the temperature displayed on the main thermostat screen to update to the new temperature.

Sensor Calibration Screen

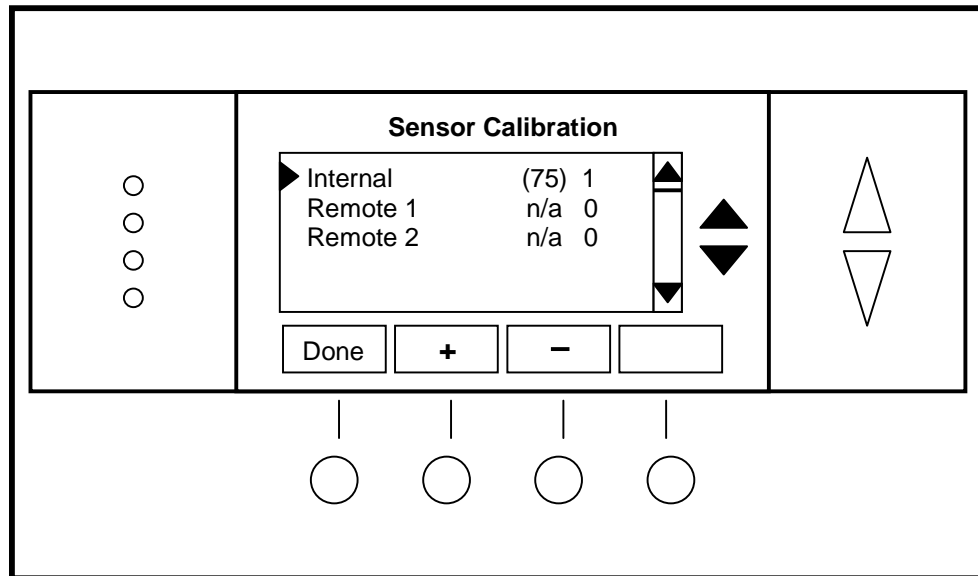

Screen navigation buttons:

Done	Return to Main Menu Screen	▲	Move menu selection pointer up
+	Increase the temperature by 1 deg		
-	Decrease the temperature by 1 deg	▼	Move menu selection pointer down
	Refresh screen temperatures		

Main Menu - User Settings - Backlite/Display

The Backlite/Display screen allows you to set the Backlite ON and OFF brightness levels and contrast.

Backlite Timeout: Sets the time from last button press that the backlite will timeout and turn off. The timeout value is adjustable from 0 or 20 to 45 seconds. If set to "0", the Backlite will always be ON. If set in the range of 20 to 45 seconds, the Backlite will turn OFF after the selected time expires.

Contrast: Sets the contrast level of the LCD display, adjustable from 0 to 20. Use this control to adjust the darkness of the display. Too light and the display looks faded, too dark and dark lines will appear in the display. Typically 10 is the correct setting. Adjust as needed.

Backlite Settings Screen

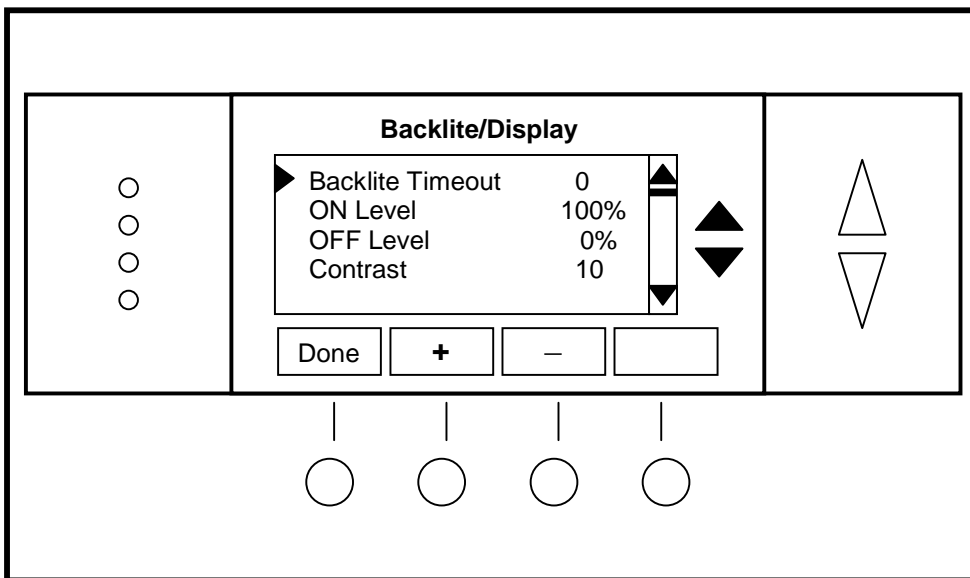

Screen Navigation Buttons



Done

Return to User Settings menu

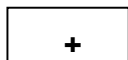

+

Increment value

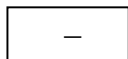

-

Decrement value

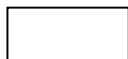

Not used



Move menu selection pointer up



Move menu selection pointer down

Main Menu - Thermostat Info

The Thermostat Info screen displays the current configuration of the TZ43 Thermostat. This information is useful for quick check of firmware versions and HVAC system setup. It also shows the Zwave network setting.

Thermostat information displayed is:

- **Thermostat** - Model and firmware version number.
- **Zwave Settings** - Zwave Firmware version, Zwave Node ID, Zwave Home ID
- **System Type** - Standard or Heatpump HVAC system
- **Fan Type** - setting *for Standard systems*: No Fan w/heat (Gas systems) or Fan w/heat (Electric systems)
OR
- **Changeover** - setting *for Heat Pump systems*: Changeover with cool or changeover with heat.

When finished viewing this screen press the **Done** button to return to the main Menu screen or wait for screen to timeout.

Thermostat Info Screen

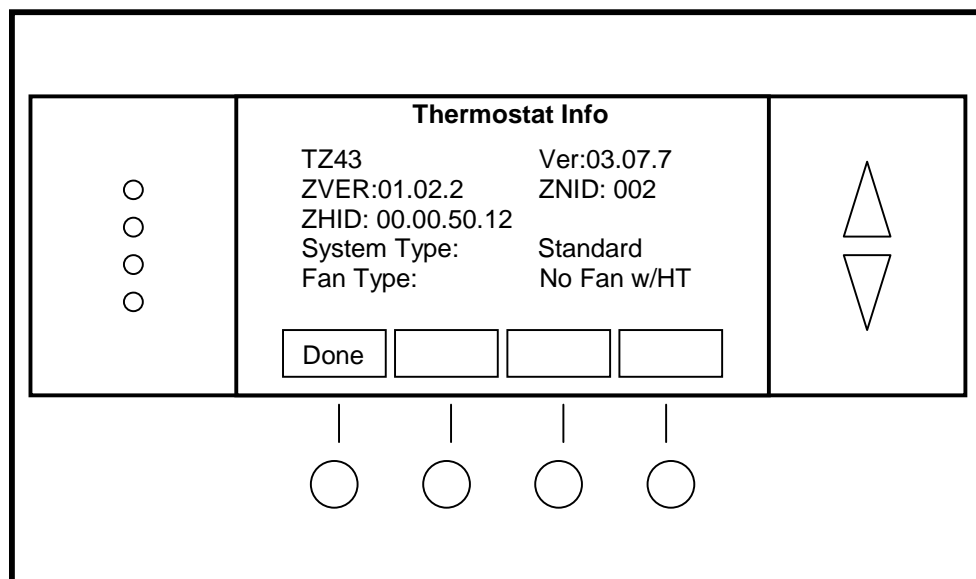

Screen navigation buttons:

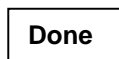

Return to Main Menu screen.

Main Menu > Installer Settings (Hidden Screen)

The Installer Settings screen is a hidden screen designed for installer use only. Do not change any settings in this screen unless you are a qualified service technician. Changing these settings will affect the operation of the heating/cooling system.

To enter this screen, go to the main menu selection screen and press and hold the two inner buttons for 3 seconds until the Installer Settings screen appears.

The Installer Settings screen displays the current internal settings of the thermostat. You can view and change the settings from this screen. Scroll to the desired function and use the +/- buttons to change.

Display Lock: Range: Y or N Default: N

Y = Display LOCKED

N = Display unlocked

Allows you to lock or unlock the thermostat buttons. When the buttons are locked, you can still access the main menu, but you will not be allowed to select any menu options. The Installer Settings hidden button operation is always operational, allowing you to return to this screen and turn Display Lock off.

Service Mode Submenu

Service Mode: Range: Y or N Default: N

Y = Service Mode On

N = Service Mode Off

Sets the thermostat timers in a test mode with short delays. All runtime and staging delays are reduced to 15 seconds to speed up system checkout and testing.

Caution: compressor short cycle protection is lost in this mode.

System Settings Submenu

Mechanical Settings Submenu

Type Range: Gas/Elec or Heatpump Default: Gas/Elec
Selects HVAC type, Gas/Electric or Heatpump

Fan Type Range: Gas or Elec Default: Gas
Selects the Fan type if system is Gas or Electric

C/O Type Range: w/Cool or w/Heat Default: w/Cool
Set the Heatpump Changeover type

2nd Stage Heat Range: Y or N Default: N
Enables the 2nd Stage Heat operation

Aux Heat (HP) Range: Y or N Default: N
Enables the Auxiliary Heat operation. Typically the Aux Heat will be heat-strips in a Heatpump system

2nd Stage Cool Range: Y or N Default: N
Enables the 2nd Stage Cool operation

Schedule Override Range: Y or N Default: N
When enabled, the scheduler function is disabled and the Run/Hold button does not appear on the main screen.

Note: The Delta T Setting is the delta, or difference between, the setpoint and current temp for determining when a heat or cool call comes on. The "delta" is the number of degrees away from setpoint.

H/C Delta Range: 3 - 15 degrees. Default: 4.
Sets the minimum separation between heating and cooling setpoints. Attempts to lower the cooling below the heating setpoint by this amount will PUSH the heating setpoint down to maintain this separation. Same for setting the heating setpoint above the cooling setpoint, it will PUSH the cooling setpoint up to maintain this separation.

Heating Delta Stage 1 ON Range: 1 to 8 degrees Default: 1
Sets the delta from setpoint that stage 1 heating starts.

Heating Delta Stage 1 OFF Range: 0 to 8 degrees Default: 0
Sets the delta from setpoint that stage 1 heating stops. Stage 1 turns off at setpoint + Delta Stage 1.

Heating Delta Stage 2 ON Range: 1 to 8 degrees Default: 4
Sets the delta from setpoint that stage 2 heating starts.

Heating Delta Stage 2 OFF Range: 0 to 8 degrees Default: 0
Sets the delta from setpoint that stage 2 heating stops. Stage 2 turns off at setpoint + Delta Stage 2.

Heating Delta Stage 3 ON Range: 1 to 8 degrees Default: 6
Sets the delta from setpoint that stage 3 heating starts.

Heating Delta Stage 3 OFF Range: 0 to 8 degrees Default: 3
Sets the delta from setpoint that stage 1 heating stops. Stage 3 turns off at setpoint + Delta Stage 3.

Cooling Delta Stage 1 ON Range: 1 to 8 degrees Default: 1
Sets the delta from setpoint that stage 1 cooling starts.

Cooling Delta Stage 1 OFF Range: 0 to 8 degrees Default: 0
Sets the delta from setpoint that stage 1 Cooling stops. Stage 1 turns off at setpoint - Delta Stage 1.

Cooling Delta Stage 2 ON Range: 1 to 8 degrees Default: 4
Sets the delta from setpoint that stage 2 cooling starts. Stage 2 turns off at setpoint.

Cooling Delta Stage 2 OFF Range: 0 to 8 degrees Default: 0
Sets the delta from setpoint that stage 2 Cooling stops. Stage 2 turns off at setpoint - Delta Stage 1.

Max Heat SP Range: 5 to 109 Default: 109
Sets the maximum heating setpoint value. Will not ramp or accept setpoints higher than this maximum. High temps are for pool/spa heating applications.

Min Cool SP Range: 6 to 110 Default: 6
Sets the minimum cooling setpoint value. Will not ramp or accept setpoints lower than this minimum. (low temps are for deg C applications)

Minimum Run Time Range: 1- 9 Minutes Default: 6
Sets the minimum run time before a heating/cooling cycle can turn off.
Sets heating/cooling cycle time. Prevents rapid cycling.

Minimum Off Time Range: 5-9 Minutes Default: 6

Sets the minimum off time before another heating/cooling cycle can begin. Provides compressor short cycle protection.

Fan Cyclor Submenu

The fan cyclor function cycles the HVAC system fan for an ON period followed by an Off period continuously. Used to provide minimum air ventilation requirements. When the Fan ON time is set to a value greater than 0, an additional "Cyclor" FAN mode is present when pressing the FAN button.

Fan ON Time Range: 0-120 minutes Default: 0 (=OFF)

Fan OFF Time Range: 0-120 minutes Default: 20

Remote Sensors Submenu

The TZ43 can support 2 remote sensors, 10K Thermistor type. Each sensor can support several "Thermostat Curves", the most common curves being the A-Curve, Type 2 and Type 3.

RS1 Type Range: A Curve, Type 2, Type 3 Default: Type 2

Selects the 10K Thermistor curve for Remote Sensor 1. If present, Remote Sensor 1 will replace the internal sensor of the TZ43 and become the Primary temperature sensor.

RS2 Type Range: A Curve, Type 2, Type 3 Default: Type 2

Selects the 10K Thermistor curve for Remote Sensor 2. If present, Remote Sensor 2 will be averaged with the Primary sensor (either the internal or RS1). Optionally RS2 can be configured to be an Outdoor sensor (see RS2 Location).

RS2 Location Range: In or Out Default: In

RS2 can optionally be configured as an Outdoor sensor.

Zwave Install Button Submenu

Used to install/un-install the TZ43 into a Zwave Network.

Installer Settings Summary

Setting	Range	Default	
Display Lock	Y or N	N	Locks out front buttons
Service Mode	Y or N	N	Turns on service mode shortens delays to 15 seconds. CAUTION no compressor protection.
F/C Mode	C or F	F	
Screen Timeout	0-240	0	seconds
Schedule Override	Y or N	N	
Max heat setpoint	10 – 109	109	
Min cool setpoint	6 – 110	6	
Min Run Time (MRT)	1 – 9	6	
Min Off Time (MOT)	5 – 9	6	
Mechanical - Type	Std or HP	Std	
Mechanical - Fan Type	Gas or Elec	Gas	
Mechanical - C/O Type	w/Heat or w/Cool	w/Cool	
Mechanical - 2 nd Stage Heat	Y or N	N	
Mechanical - Aux Heat	Y or N	N	
Mechanical - 2 nd Stage Cool	Y or N	N	
Remote Sensor1 Type	A-curve, Type 2, Type 3	Type 2	Replaces internal sensor
Remote Sensor2 Type	A-curve, Type 2, Type 3	Type 2	Averages with primary sensor or an outside sensor if location set to Out
Remote Sensor Location	In or Out	In	
Filter Interval		300	
Maint Interval		3000	
H/C Delta	3 – 15	4	
Heat Delta Stage 1 On	1 – 8	1	
Heat Delta Stage 1 Off	0 – 8	0	
Heat Delta Stage 2 On	1 – 8	4	
Heat Delta Stage 2 Off	0 – 8	0	
Heat Delta Stage 3 On	1 – 8	6	
Heat Delta Stage 2 Off	0 – 8	3	
Cool Delta Stage 1 On	1 – 8	1	
Cool Delta Stage 1 Off	0 – 8	0	
Cool Delta Stage 2 On	1 – 8	3	
Cool Delta Stage 2 Off	0 – 8	0	
Fan Cyclers ON time	0 – 120	0	0 = Fan Cyclers OFF
Fan Cyclers Off Time	0 – 120	20	

Installer Settings Screen

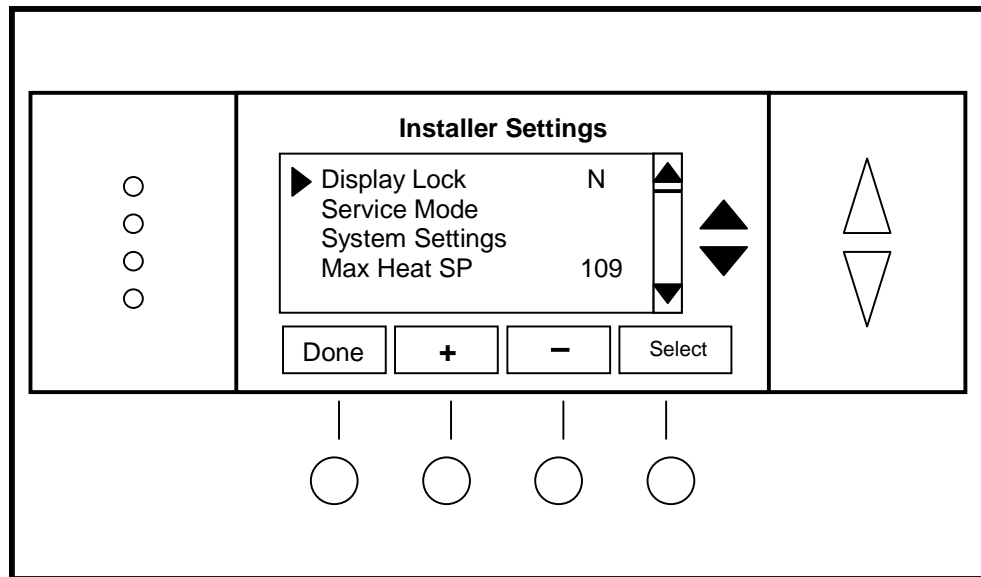

Screen navigation buttons:

Done

Return to Main Menu screen

+

Increase by 1 or change from N to Y

-

Decrease by 1 or change from Y to N

Select

Select menu item to go to a submenu



Move menu selection pointer up



Move menu selection pointer down

HVAC System Connection

The thermostat connects to the HVAC system's thermostat connections just like a traditional thermostat does.

HVAC System Compatibility

The thermostat is compatible with most heating and cooling systems. There are two types of HVAC systems: Standard (gas/electric) and Heat Pump systems. The system type is selectable from the Installer Screen – System Settings – Mechanical Settings submenu.

For Standard HVAC systems: Gas heating or Electric heating.

For Heat Pump HVAC systems: supports changeover valve operation for either changeover with cooling or changeover with heating.

Multi-Stage HVAC Compatibility

For Standard HVAC systems, the HVAC outputs support 2 stages of heating and 2 stages of cooling.

For Heat Pump HVAC systems, the HVAC outputs support 3 stages of heating (2 compressor/1 heatstrip) and 2 stages of cooling.

Remote Communications

The TZ43 thermostats have a Zwave communications module for communicating to control systems with Zwave capability.

Outside Temperature Operation

The thermostat can use and display outside temperature information from a sensor attached to the RS2 Remote Sensor connection. The outside temperature will be displayed on the Thermostat.

General Heating and Cooling Operation

In the **HEATING** mode, the heating system will be turned on at one degree below the setpoint and will turn off at the setpoint. This turn on and turn off offset is referred to as the heating setpoint “delta T” and is adjustable in the Installer Settings menu of the THERMOSTAT. It is set to the one degree operation by default.

In the **COOLING** mode, the cooling system will be turned on at one degree above the setpoint and will turn off at the setpoint. Similarly, the cooling setpoint delta T is adjustable in the Installer Settings menu.

In the **AUTO** mode, the system will switch between heating and cooling as determined by the heating and cooling setpoints and the current temperature. Once in a heating or cooling mode of operation, the normal one degree setpoint control is maintained.

Setpoint Push. Heating and cooling setpoints are forced to maintain a separation between them, with a default setting of 4 degrees. If the heating or cooling setpoint is changed to be within the setpoint delta, the system will automatically “push” the other setpoint to maintain the setpoint delta separation. The H/C setpoint delta is also adjustable in the Installer Settings menu of the THERMOSTAT.

Standard HVAC System Types

Gas or electric heating systems are considered “Standard” HVAC systems. These systems consist of an indoor furnace/blower assembly and an outdoor AC condensing unit (for those systems with air conditioning installed). These systems in general are referred to as central forced air HVAC systems.

You must configure the Thermostat to match your HVAC system type for correct system operation.

Setup

Standard System Type Selection

To configure the Thermostat for standard Gas/Electric HVAC system operation, change the **Type** in the Installer Settings – System Settings – Mechanical Settings menu option to Gas/Elec.

Fan Type Selection

Gas systems do not require a fan output for heating operation. Set the **Fan Type** in the Installer Settings – System Settings – Mechanical Settings – Fan Type to GAS.

Electric (and hydronic) heating systems **do require** a fan output with the call for heating. Set the **Fan Type** in the Installer Settings – System Settings – Mechanical Settings – Fan Type to Elec.

Be sure to check your HVAC system’s requirements.

Heat Pump HVAC System Types

Heat Pump HVAC systems are combined heating and cooling systems. The system consists of an indoor “air handler” (a blower fan and coil assembly) and an outdoor unit. Heat pumps change from heating mode to cooling mode by switching the refrigerant flow using a “changeover” or “reversing valve”. In both heating and cooling operation the compressor and fan outputs are on and the state of the changeover output determines if heating or cooling is being provided. Heat pumps can have one or two stages of compressor operation plus an optional third stage of electric heat strips.

The third stage of heating will be turned on when the current temperature falls 6 deg below the current setpoint and will turn off at 3 degrees below the setpoint.

Setup

Heat Pump System Type Selection

To set the Thermostat for Heat Pump HVAC operation, change the **Type** in the Installer Settings – System Settings – Mechanical Settings menu option to Heatpump.

Changeover Type Selection

Most heat pump systems are designed to work normally in the heating mode and require a change over output for cooling output. Change the **C/O Type** in the Installer Settings – System Settings – Mechanical Settings menu option to match your system needs.

Changeover with Cooling: Set **C/O Type** to w/Cool (This is the default setting).

Changeover with Heating: Set **C/O Type** to w/Heat.

Note: during Heat Pump operation the changeover relay, once engaged, will stay on until the opposite HVAC call occurs.

Check your HVAC system requirements for correct settings.

Minimum Run Time (MRT)

The TZ43 has a Minimum Run Time after the start of any heat or cool call. This minimum run time assures even heating and cooling cycles. Minimum Run Time will keep the system on even if you change the setpoint to a temperature that would satisfy the call, until the MRT expires. Changing the Mode to OFF will cancel the MRT and the system will turn off immediately. MRT can be adjusted in the Installer Settings Menu of the THERMOSTAT.

Note: MRT status is shown in the THERMOSTAT System Status LED on-screen label.

Minimum Off Time (MOT)

The TZ43 has a Minimum off Time after any heat or cool call. This delay prevents rapid heating/cooling cycles and also provides “short cycle protection” for compressor calls. This delay may be noticeable when you change a setpoint and it does not respond immediately due to another call that has recently completed and the MOT delay timer is preventing the restart of the system. The MOT delay time can be adjusted in the Installer Settings Menu of the THERMOSTAT. There is a minimum of 5 minutes delay to assure compressor protection.

Note: MOT status is shown in the THERMOSTAT System Status LED on-screen label.

Remote Temperature Sensors

The TZ43 can accept up to 2 remote temperature sensors. The first sensor (RS1) will replace the internal temperature sensor of the TZ43. The second sensor (RS2) can either be an averaging sensor or an Outside sensor.

Remote sensors compatible with the TZ43 need to have the following characteristics:

- 10K NTC Thermistor
- A-Curve, Type II, Type III curves

Compatible RCS Remote sensors are:

- OS5 – Outdoor Sensor (A-Curve)
- RSxx – Indoor Surface Mount (Type II)
- RSxx – Indoor Flush Mount (Type II)

Note: When using remote sensors it is important to properly configure the TZ43 for the particular sensor type. This menu option is located in *Installer Settings – Remote Sensors*. Failure to properly configure the sensor will result in in-accurate temperature readings.

Remote Sensor 1

Remote Sensor 1 (RS1) if installed will replace the internal temperature sensor of the TZ43. This allows the TZ43 to be located in a location different than the area where the temperature will be measured.

Wire specification: 2 conductors, 22Ga twisted pair or Cat 3/5 wire, 100ft maximum length

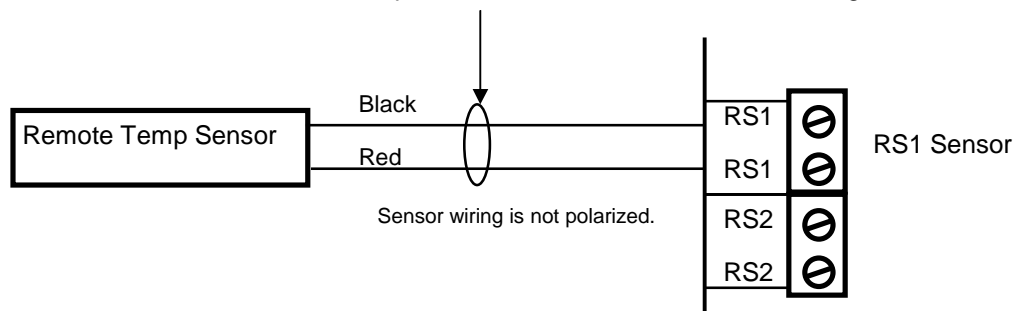

Remote Sensor 2

Remote Sensor 2 (RS2) if installed will be averaged with the primary temperature sensor (either the TZ43 internal sensor or RS1). Optionally RS2 can be configured to be an outside temperature sensor by selecting the RS2 location in the *Installer Settings – Remote Sensor* menu. When configured as an outside sensor the RS2 temperature reading will be displayed on the top of the thermostat screen.

Wire specification: 2 conductors, 22Ga twisted pair or Cat 3/5 wire, 100ft maximum length

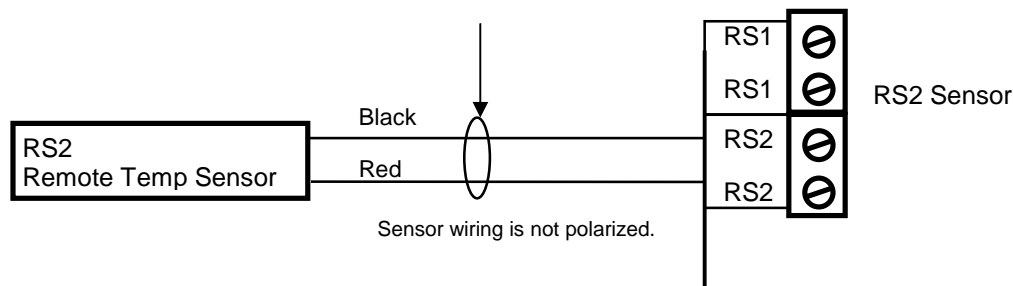

Power

The TZ43 requires 24VAC power from the HVAC system it is controlling. Connect the 24VAC Common (typically the Blue wire/terminal) and 24VAC R (typically the Red wire/terminal) from the HVAC system to the TZ43's HVAC System terminal block 24VCom and 24V RH or 24V RC terminals (the RH and RC terminals are default tied together)

Common or Split Transformer Systems

Most HVAC systems have a common heating and cooling transformer. A trace is connected to tie the RH and RC inputs together for this configuration. If you have a system with separate heating and cooling transformers, you will need to split the RH and RC jumper by cutting the trace on the PCB.

When wiring split systems, wire the heating systems 24VAC R (red wire) to the TZ43's RH terminal, and wire the cooling systems 24VAC R to the TZ43's RC terminal. Also wire the cooling systems 24VAC Com to the TZ43's 24VAC Com terminals.

Note: Do not split RC/RH for Heat Pump systems!

HVAC SYSTEM CONNECTION

Standard Gas/Electric HVAC System Wiring

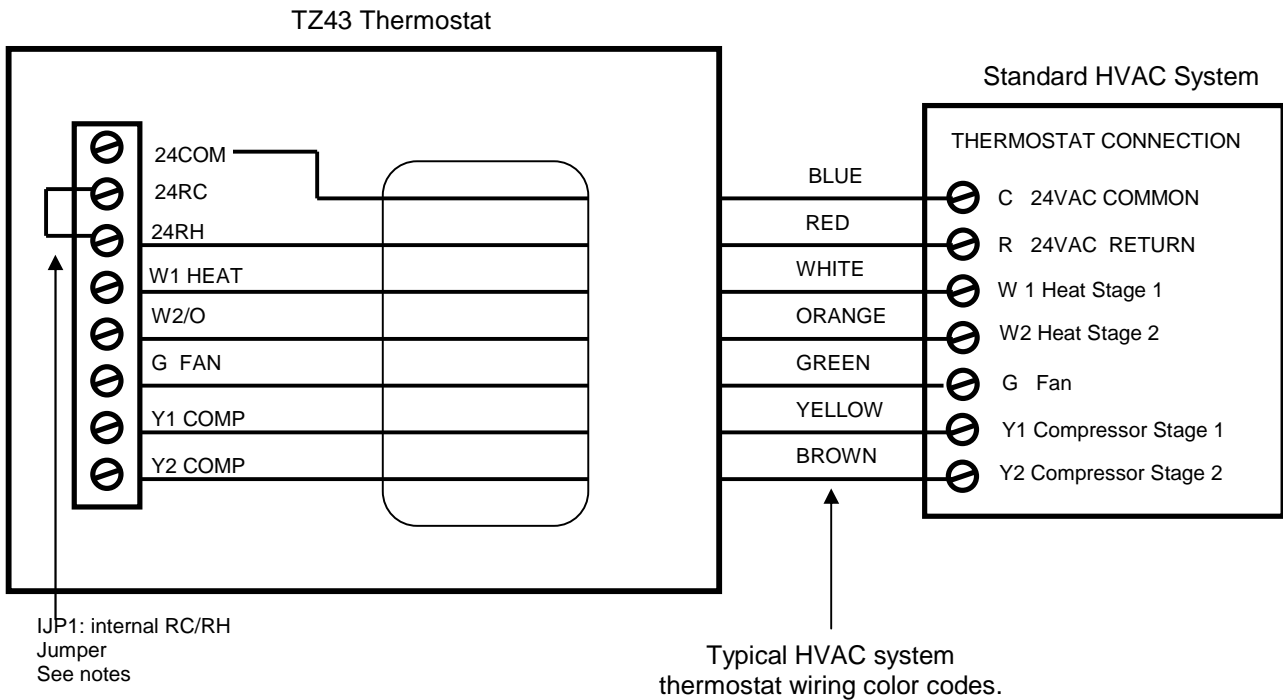

Installation Notes

Standard HVAC System Setup Notes:

Single Stage Systems use W1 for heating stage 1 and Y1 for cooling stage 1.

Two Stage Heating systems use W1 for stage 1 and W2 for stage 2 heating.

Two Stage Cooling systems use Y1 for stage 1 and Y2 for stage 2 cooling.

HVAC System 24VAC Transformer

If you have an integrated heating and cooling system with a single transformer, **do NOT cut jumper JP1**. Wire the 24V Return (red) wire to either RH or RC. This is typical of most central systems.

If you have separate heating and cooling systems with separate transformers, cut jumper JP1. Wire the heating 24V R (red) wire to the control unit's RH terminal and run the cooling systems 24V R (red) wire to control unit's RC terminal. Also wire the cooling systems 24VAC Com to the control units 24VAC Com terminal.

Heat Pump HVAC System Wiring

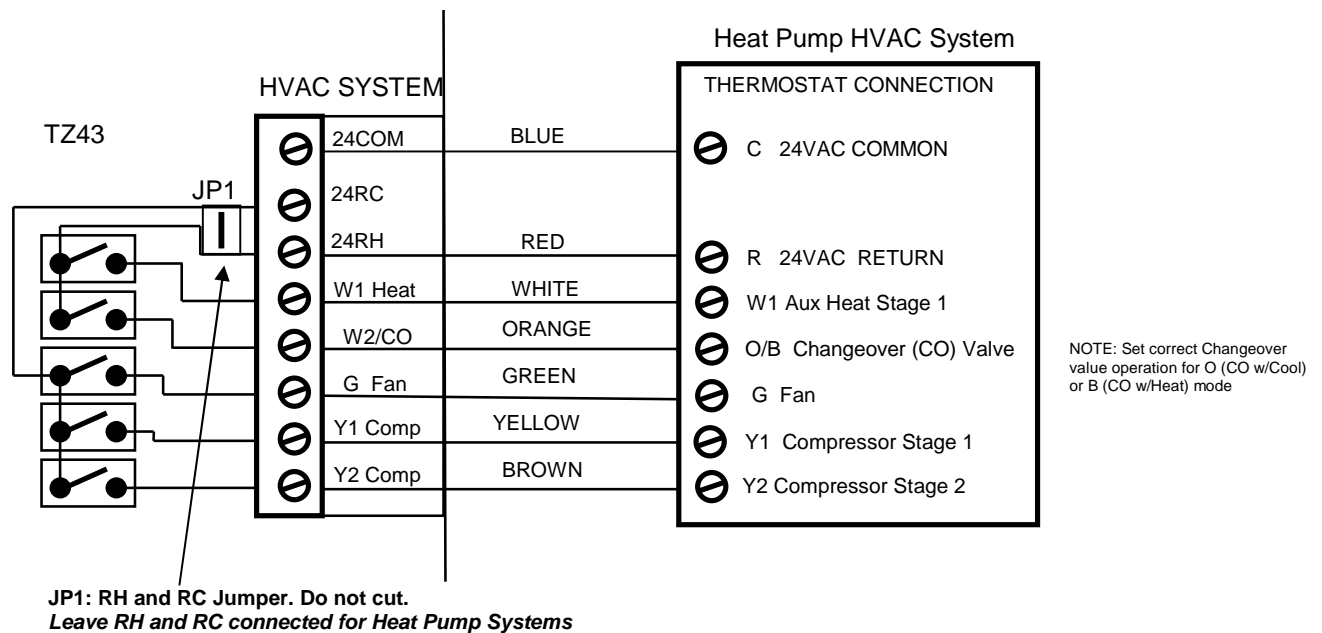

Heat Pump HVAC System Setup Notes

Single Stage Compressor Systems use **Y1 for stage 1** heating/cooling, and **W1 for stage 2** heating (heat strips).

Two Stage Compressor Systems use **Y1 for stage 1**, **Y2 for stage 2** heating/cooling, and **W1 for stage 3** heating (heat strips).

NOTE: You must configure the Changeover valve setting to work correctly with your HVAC system. Changeover settings are made in the Installer Settings – System Settings - Mechanical Settings menu. Changeover with cool is typical for most systems. Check your system information to be sure. If you get cooling when you expect heating, change the C/O type to the opposite setting.

HVAC SYSTEM QUICK TEST

If you need to verify that the HVAC system is operational, you can perform the following test

Thermostats, like the TZ43, are just switches to the HVAC system as shown in the diagram below. This is a simplified example of a thermostat and a standard HVAC wiring diagram. The HVAC system operation can be tested by duplicating the thermostat switch operation by shorting across the thermostat terminals on the HVAC system.

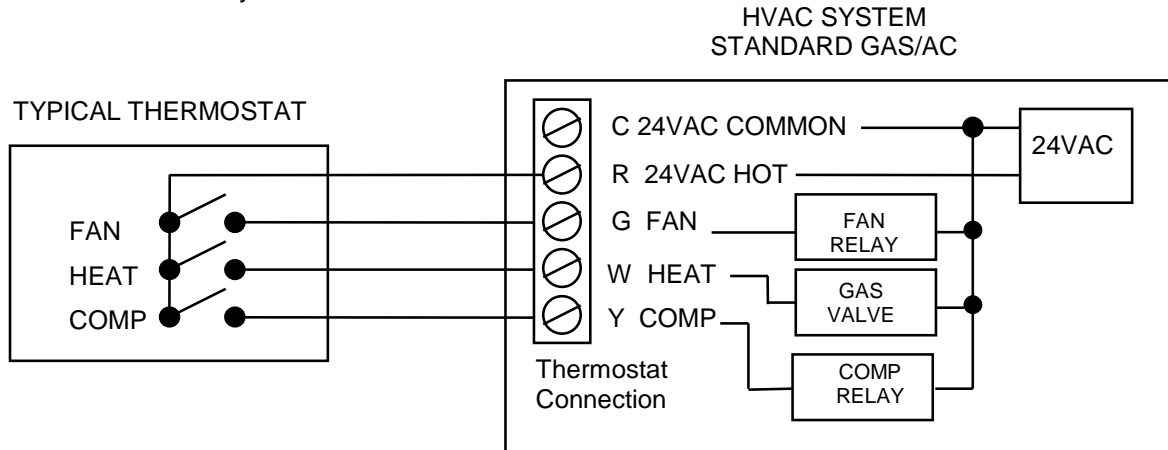

Note: The HVAC system and thermostat connection voltage is 24VAC. This is a safe voltage to work with but be careful to avoid shorting the 24VAC common (C) and 24VAC return (R) terminals. This may blow a fuse in the HVAC system.

Standard HVAC System Quick Test

You can perform a quick test of the HVAC system by shorting across the appropriate thermostat terminals on the HVAC thermostat connector. Use a short 6 inch wire to connect across the following terminals.

Function Test	HVAC Terminals	Result
Fan	R to G	Fan should come on
Heating	R to W	Heat cycle should start for heating
Cooling	R to Y and G	Compressor and Fan should start for cooling

Heat Pump System Quick Test

Similarly, you can test Heat Pump operation by shorting across the following terminals. Heat pump operation is determined by compressor calls in conjunction with changeover (O) outputs. You must know what your system CO type is (CO with Cool (typical) or CO with Heat). You should have configured the TZ43 for correct CO type, refer to this setting. Heat Pump systems have an additional O terminal.

Function Test	HVAC Terminals	Result
Fan	R to G	Fan should come on
Heating	R to Y and G	Compressor and Fan should start and Heating occurs.
Cooling	R to Y and G and O	Compressor and Fan should start. CO valve operates and Cooling occurs.

Thermostat Wiring Diagram

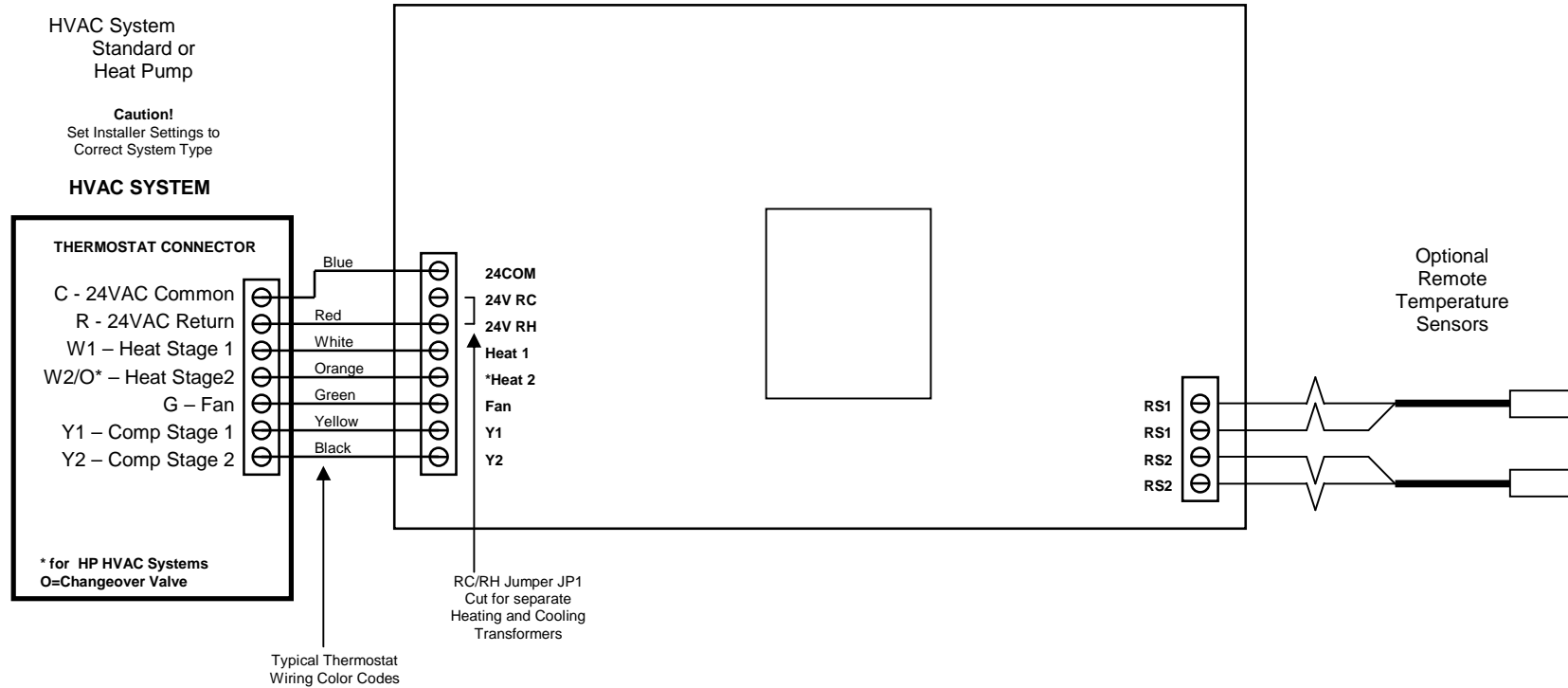

HVAC System Transformer

Most central HVAC systems have a common heating and cooling transformer. This is the factory default setting for Jumper JP1. In some cases, you may have separate heating and cooling systems, each with their own transformer. In that case, cut Jumper JP1 and wire the heating transformer red wire to the RH terminal and the cooling system transformer red wire to the RC terminal. Wire the cooling system's 24VAC Com to the TZ43's 24VAC Com terminal.

ZWave Command Class Information

The TZ43 supports the following Command Classes

Zwave Command Class	Comments
COMMAND_CLASS_THERMOSTAT_MODE	The operating mode of the TZ43 thermostat.
COMMAND_CLASS_THERMOSTAT_OPERATING_STATE	Returns the operating state of the HVAC system.
COMMAND_CLASS_THERMOSTAT_SETPOINT	The TZ43 Setpoint (heat or cool).
COMMAND_CLASS_THERMOSTAT_FAN_MODE	The Fan Mode.
COMMAND_CLASS_THERMOSTAT_FAN_STATE	The HVAC system mechanical fan state.
COMMAND_CLASS_SENSOR_MULTILEVEL	Returns the temperature as displayed by the TZ43. Note this temperature is the TZ43's working temperature and includes any averaging sensors.
COMMAND_CLASS_VERSION	Returns various Zwave version information.
COMMAND_CLASS_CLOCK	Used to set the TZ43's real-time clock.
COMMAND_CLASS_MANUFACTURER_SPECIFIC	Returns Manufacture and Product information.
COMMAND_CLASS_CONFIGURATION	Used to read/write internal TZ43 variables. The majority of the variables are accessible via the on-screen menu, the CONFIGURATION command class is used to remotely set the variables. It is recommended that you have a thorough understanding of the variables before making any changes. See variable table below.
COMMAND_CLASS_LOCK	Used to implement the Display Lock, locking the thermostat keys.

TZ43 Variable Table

Variable Number	Description	Minimum Value	Maximum Value	Notes
1	System Type	0	1	0 = Gas/Elec, 1 = HeatPump
2	Fan Type	0	1	0 = Gas, 1 = Elec
3	Change Over Type	0	1	0 = w/Cool, 1 = w/Heat
4	C/F Type	0	1	0 = C, 1 = F
9	Display Lock	0	1	0 = Unlocked, 1 = Locked
10	MOT	5	9	Minimum OFF Time
11	MRT	1	9	Minimum Run Time
12	H Delta Stage 1 On	1	8	Stage Timers
13	H Delta Stage 1 Off	0	8	
14	H Delta Stage 2 On	1	8	
15	H Delta Stage 2 Off	0	8	
16	H Delta Stage 3 On	1	8	
17	H Delta Stage 3 Off	0	8	
18	C Delta Stage 1 On	1	8	
19	C Delta Stage 1 Off	0	8	
20	C Delta Stage 2 On	1	8	
21	C Delta Stage 2 Off	0	8	
25	SB Mode	0	1	Setback mode, 0 = No Setback, 1 = Setback
69	Service Mode (Test)	0	1	0 = No Service Mode, 1 = Service Mode enabled
75	Fan Cycler ON Time	0	120	On duration of Fan Cycler
76	Fan Cycler OFF Time	0	120	Off duration of Fan Cycler
77	2nd Stage Heat Enable	0	1	0 = No 2 nd Stage Heat, 1 = 2 nd Stage Heat
78	Aux Heat Enable	0	1	0 = No Aux Heat, 1 = Aux Heat enabled
79	2nd Stage Cool Enable	0	1	0 = No 2 nd Stage Cool, 1 = 2 nd Stage Cool

